

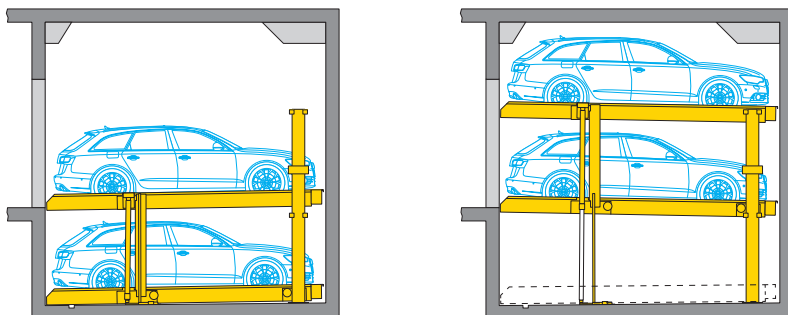

Data Sheet WÖHR Parklift 450



- **Single units: 2 cars**
Double units: 4 cars
- **Platform load options:**
 - max. 2000 kg, load per wheel 500 kg
 - max. 2600 kg, load per wheel 650 kg
- **Platform slopes for drive-on:**
 - upper level: 1° = 2% ascent
 - lower level: 1° = 2% descent
 Platform slopes help drainage

■ Height and length dimensions (underground car park)

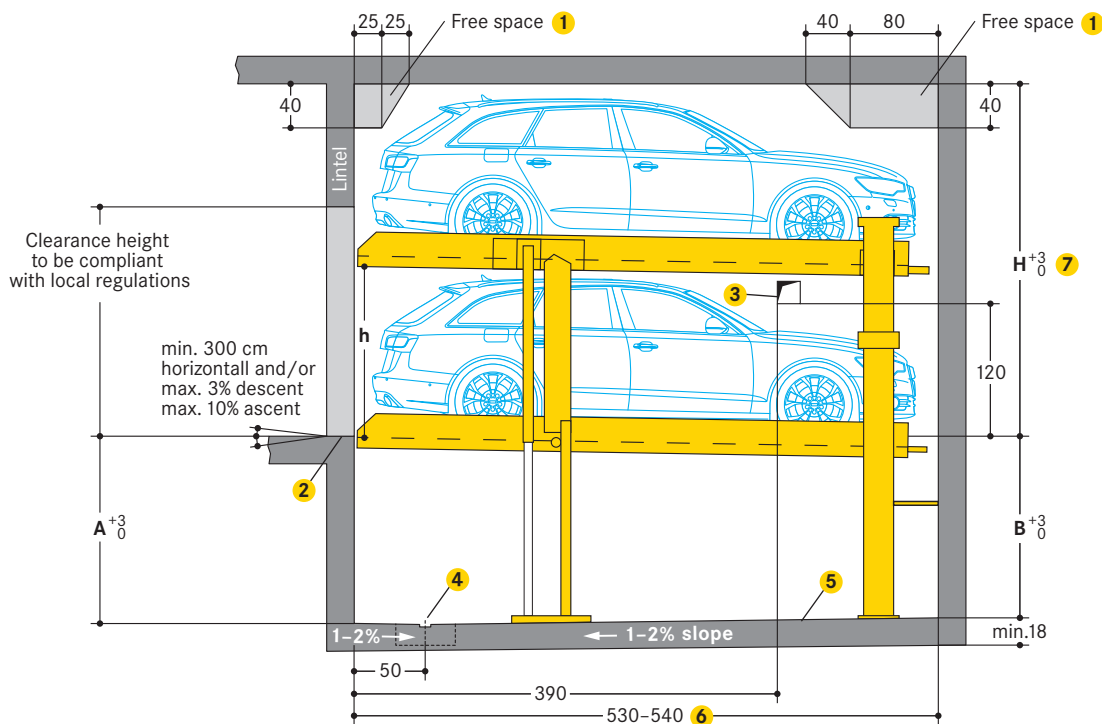

Type	Height (H) 7	Pit depth		Vehicle height 8		Platform distance (h)
		A	B	UL	LL	
450-170	320	170	165	L+S: 150	L+S: 150	155
		175	170	L+S: 150	L+S: 155	
450-175	330	175	170	L+S: 155	L+S: 155	160
		180	175	L+S: 160	L+S: 160	
450-180	340	180	175	L+S: 160	L+S: 160	165
		185	180	L+S: 165	L+S: 165	
450-185	350	185	180	L+S: 165	L+S: 165	170
		190	185	L+S: 170	L+S: 170	
450-190	360	190	185	L+S: 170	L+S: 170	175
		195	190	L+S: 175	L+S: 175	
450-195	370	195	190	L+S: 175	L+S: 175	180
		200	195	L+S: 180	L+S: 180	
450-200	380	200	195	L+S: 180	L+S: 180	185
		205	200	L+S: 185	L+S: 185	

- 1 Free spaces for any connections performed by the customer:
 - please ask WÖHR for the dimension sheets
- 2 Yellow-black safety marking:
 - compliant to ISO 3864, 10 cm wide, along the pit edges (see page 3 »Static calculations and construction works requirements«)
- 3 In case of intermediate walls:
 - 15 x 15 cm opening for electric and hydraulic system cables and piping
 - after installation, do not close the opening
- 4 Recommended drainage channels:
 - 10 x 2 cm, with a 50 x 50 x 20 cm drainage pit
 - in case of installation of a sump pump, it is necessary to comply with the drainage pit dimensions specified by the pump manufacturer
- 5 Channels or undercuts/concrete haunches:
 - not allowed along the pit floor-to-wall joints
 - should channels or undercuts be necessary, the system width needs to be reduced or the pit needs to be wider
- 6 A pit length of 540 cm is recommended. This will allow for increased safety clearances and distances also in the event of future changes to vehicle lengths.
- 7 With an increase in headroom available, correspondingly taller cars will be able to park on the upper platform.
- 8 UL= upper level / LL= lower level
L = Limousine / S = Station wagon

■ Dimensions

- all dimensions specified are the minimum, finished dimensions
- tolerances must be taken into consideration
- all dimensions are given in cm



Clearance profile (for standard vehicles)

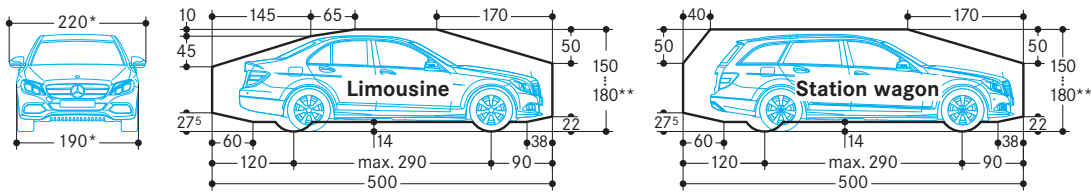

* for a 250 cm platform width
 ** The overall vehicle height including roof luggage rails and antenna mounts must not exceed the max. vehicle height dimensions specified

Width dimensions

Platform widths:

250 cm (single units), 500 cm (double units):
 - for 190 cm vehicle width

260–270 cm (single units), 520–540 cm (double units):

- for vehicles wider than 190 cm
 - for units with intermediate walls
 - for units at the end of the driving aisle

In case of reduced maximum platform widths:

- when parking wider vehicles or two-door sports car models, there may be difficulties in climbing in and out of the vehicle, depending on the type of vehicle, on how the entrance area is arranged and on individual driving habits

Width dimensions (underground car park)

Intermediate walls

Single unit (2 cars)



Space requirements	clear platform width
B	
260	230
270	240
280	250
290	260
300	270

Double unit (4 cars)

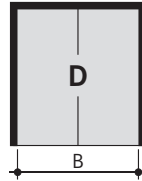

Space requirements	clear platform width
B	
490	460
510	480
530	500
550	520
570	540

Combined unit (6 cars)

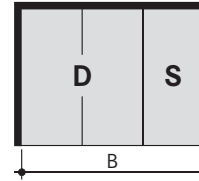

Space requirements	clear platform width
B	
750	460+230
780	480+240
810	500+250
840	520+260
870	540+270

The driving aisle width must comply with local regulations

It is possible to combine different widths

Columns external to the pit

Single unit (2 cars)

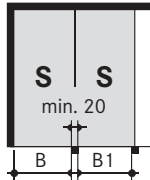

Space requirements	clear platform width	
wall-column B	column-column B1	
250	240	230
260	250	240
270	260	250
280	270	260
290	280	270

Double unit (4 cars)

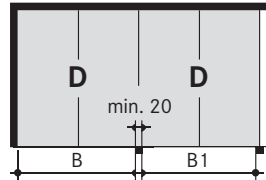

Space requirements	clear platform width	
wall-column B	column-column B1	
480	470	460
500	490	480
520	510	500
540	530	520
560	550	540

Combined unit (6 cars)

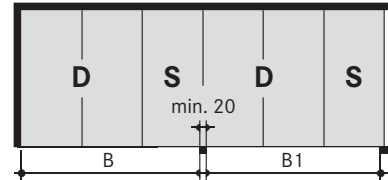

Space requirements	clear platform width	
wall-column B	column-column B1	
740	730	460+230
770	760	480+240
800	790	500+250
830	820	520+260
860	850	540+270

The driving aisle width must comply with local regulations

It is possible to combine different widths

Columns in the pit

Single unit (2 cars)

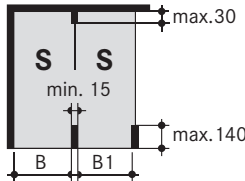

Space requirements	clear platform width	
wall-column B	column-column B1	
255	245	230
265	255	240
275	265	250
285	275	260
295	285	270

Double unit (4 cars)

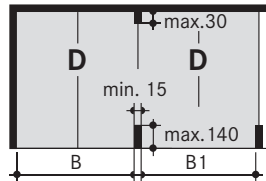

Space requirements	clear platform width	
wall-column B	column-column B1	
485	475	460
505	495	480
525	515	500
545	535	520
565	555	540

Combined unit (6 cars)

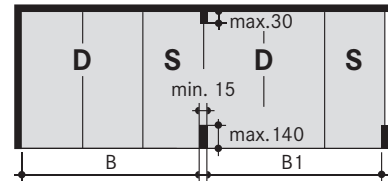

Space requirements	clear platform width	
wall-column B	column-column B1	
745	735	460+230
775	765	480+240
805	795	500+250
835	825	520+260
865	855	540+270

The driving aisle width must comply with local regulations

It is possible to combine different widths

Garages with doors

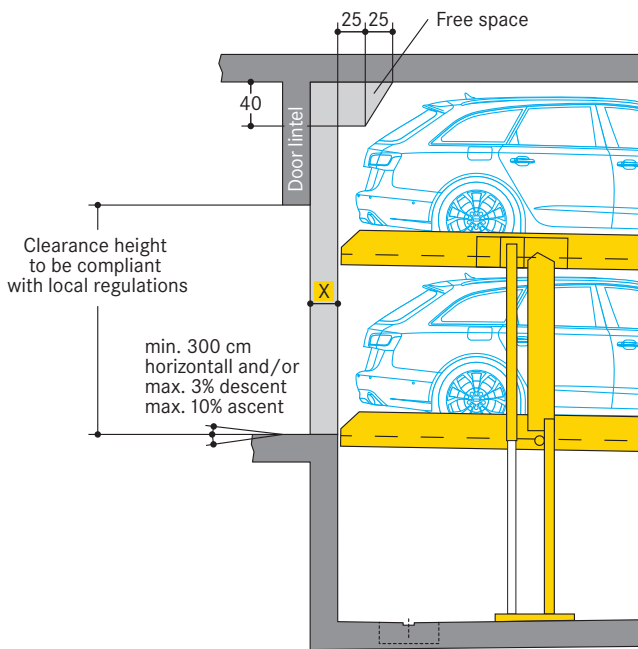

X = 10/15 cm for roller shutters

Dimension X to be defined by customer with the door supplier.

Single unit (2 cars)

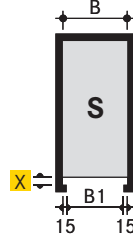

Garage rows with single doors (2 cars each)

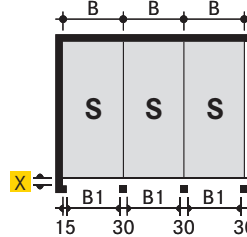

Space requirements		clear platform width
B	B1*	
260	230	230
270	240	240
280	250	250
290	260	260
300	270	270

* B1 = drive-in passage width

Double unit (4 cars)

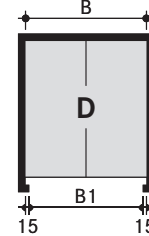

Garage rows with double doors (4 cars each)

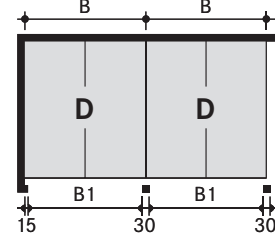

Space requirements		clear platform width
B	B1*	
490	460	460
510	480	480
530	500	500
550	520	520
570	540	540

Operating panel recesses and empty piping requirements

Flush mounted

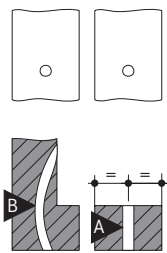

Recess mounted

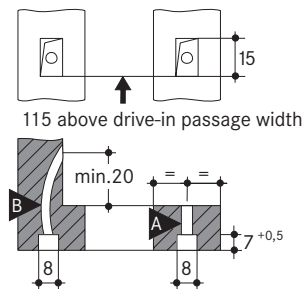

A M20 plastic or steel-armoured piping

B M20 flexible, plastic-insulated piping

Static calculations and construction works requirement

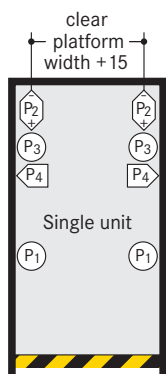

Safety marking compliant to ISO 3864

P1	+ 43 kN*
	- 14 kN
P2	+ 4 kN
	- 4 kN
P3	+ 17 kN
	- 3 kN
P4	+ 3 kN

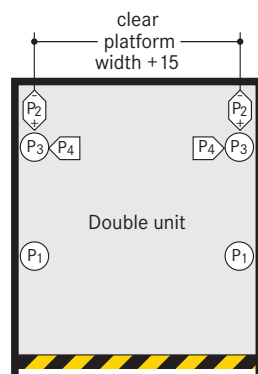

P1	+ 75 kN*
	- 24 kN
P2	+ 4 kN
	- 4 kN
P3	+ 28 kN
	- 3 kN
P4	+ 3 kN

* specified load bearing data includes the vehicle weight

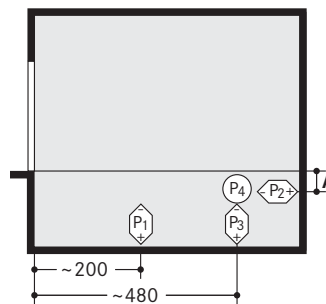

Fixing of the system frames to the floor slab:

- using base plates (approx. 140 cm²)
- using adhesive anchor bolts
- hole depth to 10-12 cm
- concrete thickness of at least 18 cm

Concrete quality grade:

- compliant to the static requirements of the construction
- min. C20/25 grade (for dowel fastening)

Walls:

- front drive-in wall and rear wall in concrete
- perfectly flat wall surfaces
- without protruding sections such as border edgings, pipes and tubes, etc.

Frame bearing points:

- the specified lengths are expressed as mean value
- for the exact data, specific TÜV-tested data sheets are available

	A
Parklift 450-170	0
Parklift 450-175	5
Parklift 450-180	10
Parklift 450-185	15
Parklift 450-190	20
Parklift 450-195	25
Parklift 450-200	30

Extra space for hydraulic power packs

Dimensions in cm	1-5 Parklifts	6-10 Parklifts
Length:	100	150
Height:	140	140
Depth:	35	35

Hydraulic power pack placement options:

- located either on the top platform so that it moves with unit or on the wall
- where this is not possible, it is necessary to arrange for an extra space above drive-in level (i.e. for a wall recess or a niche)

Electrical specifications

To be performed by the customer

Item	Quantity	Description	Position	Recurrence
1	1 piece	power meter	in the feed cable	
2	1 piece	fuse protection or automatic circuit breaker compliant to DIN VDE 0100 part 430: 3 x 16 A slow blow for 3,0 kW 3 x 25 A slow blow for 5,5 kW	in the feed cable	1 x per power pack
3	based on site conditions	compliant to local power supply regulations 3 phases + N + PE*	feed cables to main switch	1 x per power pack
4	every 10m	equipotential bonding safety lead-out connection	along pit floor edges/ rear wall	
5	1 piece	equipotential bonding safety compliant to DIN EN 60204	from lead-out connection to system	1 x per system

* to DIN VDE 0100 sections 410 and 430 (no permanent load) 3 phases + N + PE (three phase current)

Note: for garages with doors the door manufacturer must be consulted before the electrical feed cabling is laid.

Scope of delivery by WÖHR

(unless as otherwise specified in the relative offer/contract)

Item	Description
6	Lockable main switch
7	5 x 2,5 ² PVC control cable leading from the main switch to the power pack
8	Hydraulic power pack with three-phase motor, 3.0 or 5.5 kW. Ready-wired switching cabinet with motor safety contactor
9	5 x 1,5 ² PVC control cable
10	Branch connector
11	5 x 1,5 ² PVC control cable lead-out to the system alongside
12	UP/down operating unit with EMERGENCY STOP. Possibly located on the left, but always out of the platform's range of movement. Cable feed-in strictly from below leading upwards (2 keys for each parking space)..
13	7 x 1,5 ² PVC control cable
14	3 x 1,5 ² control cable for the cylinder valve lead

Notes and directions

Scope of application

- suitable for residential buildings, office buildings and business premises, hotels
- only for long-term users that have been instructed on how to use the system
- for frequently changing users (e.g. for office, hotel and business premises or similar):
 - only use of the top platform is possible
 - performance of technical system adjustments is necessary
 - consultation with WÖHR is mandatory

Noise protection

Foundations:
- to the German DIN 4109 »Noise protection in buildings«

Requirements for maintaining a max. 30 dB(A) sound pressure level in living quarters:

- noise protection kit available as an optional WÖHR accessory
- overall building sound insulation to be min. $R_w = 57$ dB
- single-pane (monocoque) construction of the parking system border walls, with a flex rigidity of min. $m' = 300$ kg/m²
- overall parking system solid ceiling slab of min. $m' = 400$ kg/m²

Implementation of additional noise protection measures in the event of changes or amendments to the construction requirements.

The best results are given by installing system base plates separated from the actual construction.

For increased noise protection:

- airborne sound insulation values compliant to the DIN 4109-10
- increased noise protection levels need to be pre-planned and confirmed by WÖHR to project requirements (increased construction dimensions are necessary)

Drainage

Water leaks into the pit:

- in the winter, up to 40 litres of snow water can come with the wheel housings in just one parking process

Recommended drainage channels:

- along the front end sections of the pit
- connecting to a floor drain or drainage pit (50 x 50 x 20 cm)
- with manual emptying out of the drainage pit
- alternatively installation of a pump or drainage channel into the sewerage system, to be performed by the customer

Sideways slope drainage:

- only into a gutter
- not possible in the remaining pit section

Lengthways slope drainage:

- provided according to specified construction dimensions

Environmental safety:

- coating of the pit flooring is recommended
- installation of an oil and/or petrol separator unit between the drainage connection and the main sewerage system

Lighting

- sufficient lighting of the driving aisle and of the parking places must be performed by the customer

Installation diagram

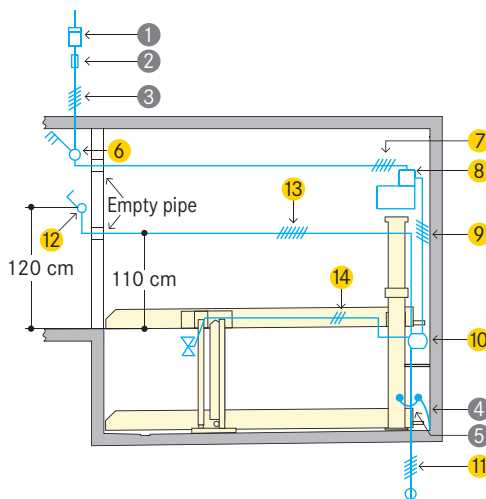

Cabling preparation to be performed by the customer:

- up to the main switch to be in place prior to starting the installation operations
- connection to the main switch during installation
- system functional check testing can be performed by WÖHR together with the electrician provided by the customer
- if requested at a later date, functional check testing can be performed by WÖHR at extra-cost

Equipotential bonding safety:

- to be performed by the customer compliant to DIN EN 60204
- connections required every 10 metres

Temperature

- system operating range: -10° to +40°C (with unloaded platforms lowering speed is reduced if less than +5° C)
- humidity: 50% at +40°C
- in the event of changes to system conditions please consult with WÖHR accordingly

Declaration of conformity

The parking systems are compliant to:
- EC Machinery Directive 2006/42/EC
- DIN EN 14010

Railings

Wherever construction gaps and openings exceed permissible dimensions (to local, country-specific requirements):

- the system must feature safety railings

In the event of walkways/traffic passageways running directly alongside or behind the Parklifts and/or systems positioned along border walls:

- safety fences and barriers compliant to DIN EN ISO 13857 must be performed by the customer (also during the construction phases).

Maintenance

- WÖHR and all the WÖHR partners abroad provide an installation and customer service network
- regular, annual maintenance is provided subject to the stipulation of a maintenance agreement

Prevention of corrosion damage

- all operations listed in the WÖHR Cleaning and Maintenance Instructions are to be performed regularly (independently of maintenance operations)
- zinc-plated parts, components and platforms are to be kept clean of dirt, road-salt and any other debris (due to corrosion hazards)
- always keep the garage well ventilated and deaerated

Fire safety

- all fire safety requirements and all mandatory equipment (fire extinguisher and fire alarm systems, etc.) must be performed by the customer

Construction formalities

- the documentation necessary for construction permit applications is provided by WÖHR

Construction alterations and/or modifications

- the right to construction or model modifications and/or variations is hereby reserved
- the right to any subsequent part modification and/or variation and amendments in procedures and standards due to technical and engineering progresses or due to environmental regulation changes is also hereby reserved